

5-25-2017

Operating Temperature of a Solar Thermal Stirling Engine

Spencer Beck
Linfield College

Follow this and additional works at: https://digitalcommons.linfield.edu/physstud_theses

 Part of the [Engineering Physics Commons](#), [Power and Energy Commons](#), and the [Semiconductor and Optical Materials Commons](#)

Recommended Citation

Beck, Spencer, "Operating Temperature of a Solar Thermal Stirling Engine" (2017). *Senior Theses*. 28.
https://digitalcommons.linfield.edu/physstud_theses/28

This Thesis (Open Access) is protected by copyright and/or related rights. It is brought to you for free via open access, courtesy of DigitalCommons@Linfield, with permission from the rights-holder(s). Your use of this Thesis (Open Access) must comply with the [Terms of Use](#) for material posted in DigitalCommons@Linfield, or with other stated terms (such as a Creative Commons license) indicated in the record and/or on the work itself. For more information, or if you have questions about permitted uses, please contact digitalcommons@linfield.edu.

Operating Temperature of a Solar Thermal Stirling Engine

Spencer T. Beck

A THESIS

Presented to the Department of Physics
LINFIELD COLLEGE
McMinnville, Oregon

In partial fulfillment of the requirements
for the Degree of

BACHELOR OF SCIENCE

May, 2017

THESIS COPYRIGHT PERMISSIONS

Please read this document carefully before signing. If you have questions about any of these permissions, please contact the [DigitalCommons Coordinator](#).

Title of the Thesis:

Operating Temperature of a Solar Thermal Stirling Engine

Author's Name: (Last name, first name)

Beck, Spencer

Advisor's Name

Bill Mackie

DigitalCommons@Linfield is our web-based, open access-compliant institutional repository for digital content produced by Linfield faculty, students, staff, and their collaborators. It is a permanent archive. By placing your thesis in DigitalCommons@Linfield, it will be discoverable via Google Scholar and other search engines. Materials that are located in DigitalCommons@Linfield are freely accessible to the world; however, your copyright protects against unauthorized use of the content. Although you have certain rights and privileges with your copyright, there are also responsibilities. Please review the following statements and identify that you have read them by signing below. Some departments may choose to protect the work of their students because of continuing research. In these cases, the project is still posted in the repository but content will only be accessible by individuals who are part of the Linfield community.

CHOOSE THE STATEMENT BELOW THAT DEFINES HOW YOU WANT TO SHARE YOUR THESIS. THE FIRST STATEMENT PROVIDES THE MOST ACCESS TO YOUR WORK; THE LAST STATEMENT PROVIDES THE LEAST ACCESS.

I agree to make my thesis available to the Linfield College community and to the larger scholarly community upon its deposit in our permanent digital archive, DigitalCommons@Linfield, or its successor technology. My thesis will also be available in print at Nicholson Library and can be shared via interlibrary loan.

OR

I agree to make my thesis available only to the Linfield College community upon its deposit in our permanent digital archive, DigitalCommons@Linfield, or its successor technology. My thesis will also be available in print at Nicholson Library and can be shared via interlibrary loan.

OR

I agree to make my thesis available in print at Nicholson Library, including access for interlibrary loan.

OR

I agree to make my thesis available in print at Nicholson Library only.

NOTICE OF ORIGINAL WORK AND USE OF COPYRIGHT-PROTECTED MATERIALS:

If your work includes images that are not original works by you, you must include permissions from original content provider or the images will not be included in the repository. If your work includes videos, music, data sets, or other accompanying material that is not original work by you, the same copyright stipulations apply. If your work includes interviews, you must include a statement that you have the permission from the interviewees to make their interviews public. For information about obtaining permissions and sample forms, see <http://copyright.columbia.edu/copyright/permissions/>.

NOTICE OF APPROVAL TO USE HUMAN SUBJECTS BY THE LINFIELD COLLEGE INSTITUTIONAL RESEARCH BOARD (IRB):

If your research includes human subjects, you must include a letter of approval from the Linfield IRB. For more information, see <http://www.linfield.edu/irb/>.

NOTICE OF SUBMITTED WORK AS POTENTIALLY CONSTITUTING AN EDUCATIONAL RECORD UNDER FERPA:

Under FERPA (20 U.S.C. § 1232g), this work may constitute an educational record. By signing below, you acknowledge this fact and expressly consent to the use of this work according to the terms of this agreement.

BY SIGNING THIS FORM, I ACKNOWLEDGE THAT ALL WORK CONTAINED IN THIS PAPER IS ORIGINAL WORK BY ME OR INCLUDES APPROPRIATE CITATIONS AND/OR PERMISSIONS WHEN CITING OR INCLUDING EXCERPTS OF WORK(S) BY OTHERS.

IF APPLICABLE, I HAVE INCLUDED AN APPROVAL LETTER FROM THE IRB TO USE HUMAN SUBJECTS.

Signature Signature redacted Date 05/25/17

Printed Name Spencer Beck

Approved by Faculty Advisor Signature redacted Date 8/8/17

Thesis Acceptance

Linfield College

Thesis Title: Operating Temperature of a Solar Thermal Stirling Engine

Submitted by: Spencer Beck

Date Submitted: May, 2017

Thesis Advisor: *Signature redacted* _____

Dr. Mackie

Physics Department: *Signature redacted*

Signature redacted
Dr. Murray

Physics Department: *Signature redacted* /
/ _____

Dr. Xie

ABSTRACT

Operating Temperature of a Solar Thermal Stirling Engine

This paper explores the relationship between the operating temperature and electricity production of a simple heat engine. A Stirling engine was designed and constructed which runs on solar thermal energy collected by a Fresnel lens. The surface area of the solar collector was varied. This manipulated the operating temperature of the Stirling engine in order to measure power output. The mechanical energy from the engine was converted to electricity using a DC motor running in reverse, acting like a generator, in conjunction with an Arduino for data collection. Although adjustments must be made in order to improve the efficiency of the system, the data show a significant increase in power output in relation to thermal energy around the temperature range of 120-160°C range.

Contents

1	Introduction	1
1.1	Stirling Engines	1
1.2	Solar Thermal Energy	2
1.3	Solar Cells	3
2	Background	4
2.1	Radiative Heat Transfer	4
2.2	Electricity Generation	5
3	Methods	8
3.1	Stirling Engine	9
3.2	Solar Collector	9
3.3	Arduino Data Collection	10
4	Results	12
4.1	Data Collected	12
4.2	Analysis	13
5	Conclusion	15
5.1	Sources of Uncertainty	17
5.2	Future Work	17
6	Appendix	18
6.1	Sample Arduino Code	18
7	Acknowledgements	20
	REFERENCES	21

List of Figures

1.1	Solar power tower	2
2.1	A.C. generator	6
2.2	EMF sine wave	7
3.1	Experimental setup	8
3.2	Stirling engine	9
3.3	Fresnel lens	10
3.4	Circuit diagram	11
4.1	Data	12
4.2	Time-dependent data	13
4.3	Rectified A.C. output	14
5.1	Data with trend line interpretation	16

Chapter 1

Introduction

It is essential that alternatives for electricity production are researched and tested in order to improve efficiencies and reduce the cost of energy. Solar cells are a commonly used form of renewable energy, but are limited by the availability of sunlight. Alternative energy production facilities which use thermal batteries can fill in the power gaps made by other forms which are limited to hour-by-hour availability of resources. This paper explores the relationship between the operating temperature and energy production of a solar thermal Stirling engine and addresses the issues related to the efficiency of such a system.

1.1 Stirling Engines

Stirling engines are simple heat engines which use the expansion and compression of a gas to create mechanical energy through the irreversible Stirling air cycle [1][2]. This mechanical energy can then be converted to electrical energy by means of rotational motion and an electric generator. Stirling engines are particularly useful since the energy source is external and can therefore utilize any type of thermal energy.

1.2 Solar Thermal Energy

Solar thermal electricity generators use solar radiation as the driving heat source for an engine. The process in which these systems typically produce electricity occurs in several steps. A solar concentrator, in most cases a parabolic mirror, focuses sunlight to a pipe in which a liquid salt solution flows [3]. The thermal energy from the light heats the liquid as it flows to a Stirling engine or boiler to produce mechanical power. This mechanical power is then converted to electricity using a generator [1].

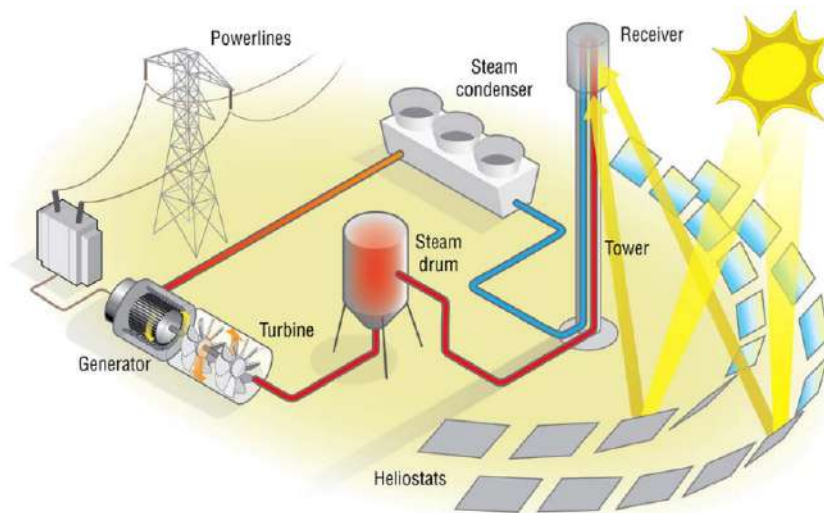

Figure 1.1: Solar power tower diagram. The mirrors focus sunlight to the central tower which houses thermal pipes containing the liquid salt solution. The Ivanpah Solar Power Facility follows this design [4].

Another system currently in use focuses sunlight with arrays of thousands of mirrors to a single tower which houses the thermal pipes [3]. One such design can be found at the Ivanpah Solar Power Facility near Ivanpah, California[3], as seen in Figure 1.1. Solar thermal power facilities are also efficient since the energy can be stored in a type of thermal battery which utilizes the heat capacity of the salt solution, reserving the thermal energy to be later converted into mechanical and electrical energy [3].

1.3 Solar Cells

Solar thermal engines can be used as an alternative to solar cells for energy production. Solar cells rely on the photovoltaic effect, where a material produces a voltage when exposed to light. However, a large portion of land must be covered with solar cells in order to produce a significant amount of power. This form of alternative energy requires a great deal of maintenance on expensive, inefficient solar cells.

Although sunlight incident to earth includes 77% of the entire solar spectrum, much less can be converted into usable energy [5]. In practice, around 43% of the photon energy heats the solar cell [5]. In fact, at 0°C, the maximum theoretical efficiency of a solar cell is 24% [5]. This drops with an increase in operating temperature to just 14% at 100°C [5]. At most times the efficiency hovers between 10-14% [5]. This is an obvious limitation since solar cells will obviously increase in temperature the longer that they are in operation.

Alternatively, in order to run a large-scale solar thermal electricity generator, there can be one engine and many mirrors to collect the light, such as at Ivanpah. These mirrors are cheaper and require less maintenance than solar cells of equal size and land coverage.

Chapter 2

Background

2.1 Radiative Heat Transfer

Solar thermal engines rely on thermal conductivity and radiative heat transfer for energy generation. Stefan's law was used in order to understand radiative heat transfer from sunlight to the Stirling engine. This states the relationship between power radiated by and the temperature of a material [6]. It is thus possible to determine the power (P) radiated by an object:

$$P = \sigma eAT^4 \tag{2.1}$$

Where e is the emissivity coefficient of the object, σ is the Stefan-Boltzmann constant ($5.6703 \cdot 10^{-8} \text{ W} \cdot \text{m}^{-2} \cdot \text{K}^{-4}$), and A is the area of the emitting body (m^2) [6]. Notice, for an ideal black body the emissivity coefficient is 1.

The amount of radiation emitted by the sun and received by the earth is known as the solar constant S ($1370 \text{ W} \cdot \text{m}^{-2}$) [6]. This constant is taken as an assumption since this power will vary depending on location, weather, season, and other general atmospheric factors. Therefore the solar power absorbed by an object on earth in direct sunlight is:

$$P_{absorbed} = SA_i \tag{2.2}$$

Where S is the solar constant and A_i is the area of the object incident to the sunlight.

The total power emitted from an object is given by the following:

$$P_{emitted} = \sigma A_{tot} T^4 \tag{2.3}$$

Where A_{tot} is the total surface area of the object and σ and T are as previously defined [6]. These two equations, 2.2 and 2.3, can be set equal to each other in order to determine the average temperature of the object over a prolonged period of time, replacing T with T_{avg} :

$$T_{avg} = \left(\frac{SA_i}{\sigma A_{tot}} \right)^{\frac{1}{4}} \tag{2.4}$$

This is of interest to determine the average maximum operating temperature of the piston of the Stirling engine which is incident to the sunlight. Since a lens is used to focus sunlight to the engine, the incident area A_i is equal to the area of the Fresnel lens used in the experiment: approximately 0.056 m^2 as measured. The total area A_{tot} of the piston is approximately 0.0014 m^2 as measured. Plugging in the necessary information to equation 2.4 gives an average temperature of approximately 990K, or 720°C, assuming optimal thermal efficiency.

2.2 Electricity Generation

Mechanical energy is converted to electricity by alternators or generators using electromagnetic induction. On the most basic level, these consist of a tightly-wound coil of wire which rotates on an axle in a magnetic field produced by permanent magnets. As the axle spins, alternating current is induced in the coil.

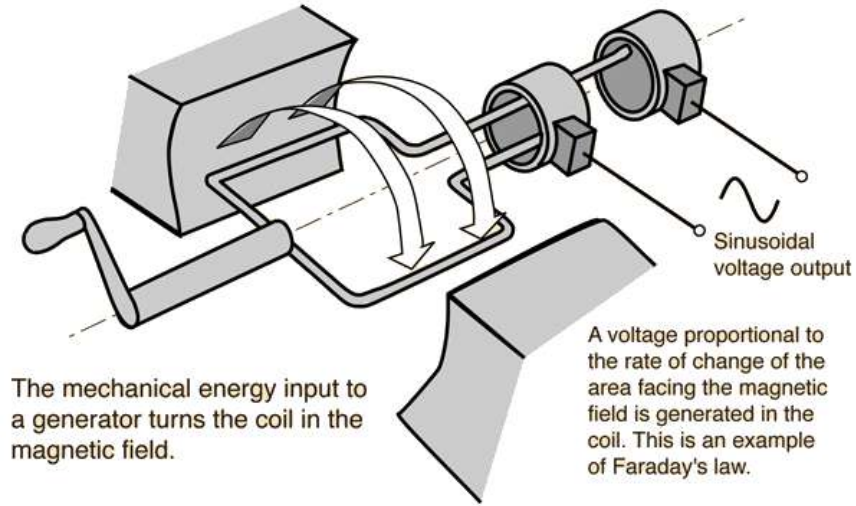

Figure 2.1: Alternating current generator. A coil rotates within a magnetic field to produce a sinusoidal voltage output [7].

Electromotive force (emf ε or otherwise known as voltage v) can be calculated by doing the following derivation:

$$\Phi = \int \vec{B} \cdot d\vec{a} \quad (2.5)$$

$$\Phi = BA \cos \theta$$

Equation 2.5 refers to the flux due to a magnetic field through a given surface defined by a $d\vec{a}$. B is the magnitude of the magnetic field and A is the area πR^2 enclosed by the coil where R is the radius of the coil, θ is the angle between the magnetic field and the plane of the coil. In this case, $\theta = \omega t$, where ω is the angular velocity of the rotating coil within the AC generator. Therefore, by substitution:

$$\Phi = B\pi R^2 \cos \omega t$$

Which allows for the calculation of the emf ε :

$$\varepsilon = -\frac{d\Phi}{dt} \quad (2.6)$$

$$\varepsilon(t) = -\frac{d}{dt}(B\pi R^2 \cos \omega t) = B\pi R^2 \omega \sin \omega t \quad (2.7)$$

Thus, the output of $\varepsilon(t)$ will resemble the form of Figure 2.2:

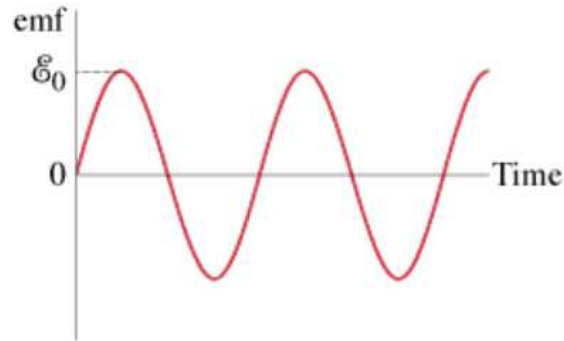

Figure 2.2: Amplitude $\varepsilon_0 = B\pi R^2 \omega$.

As time progresses and the loop of wire spins in the magnetic field, the voltage output is a sinusoidal function. This is known as alternating current, or A.C..

Chapter 3

Methods

The experiment required a Stirling engine, a Fresnel lens, Arduino UNO microcontroller, DC motor, thermocouple, and other circuitry as listed in each section below.

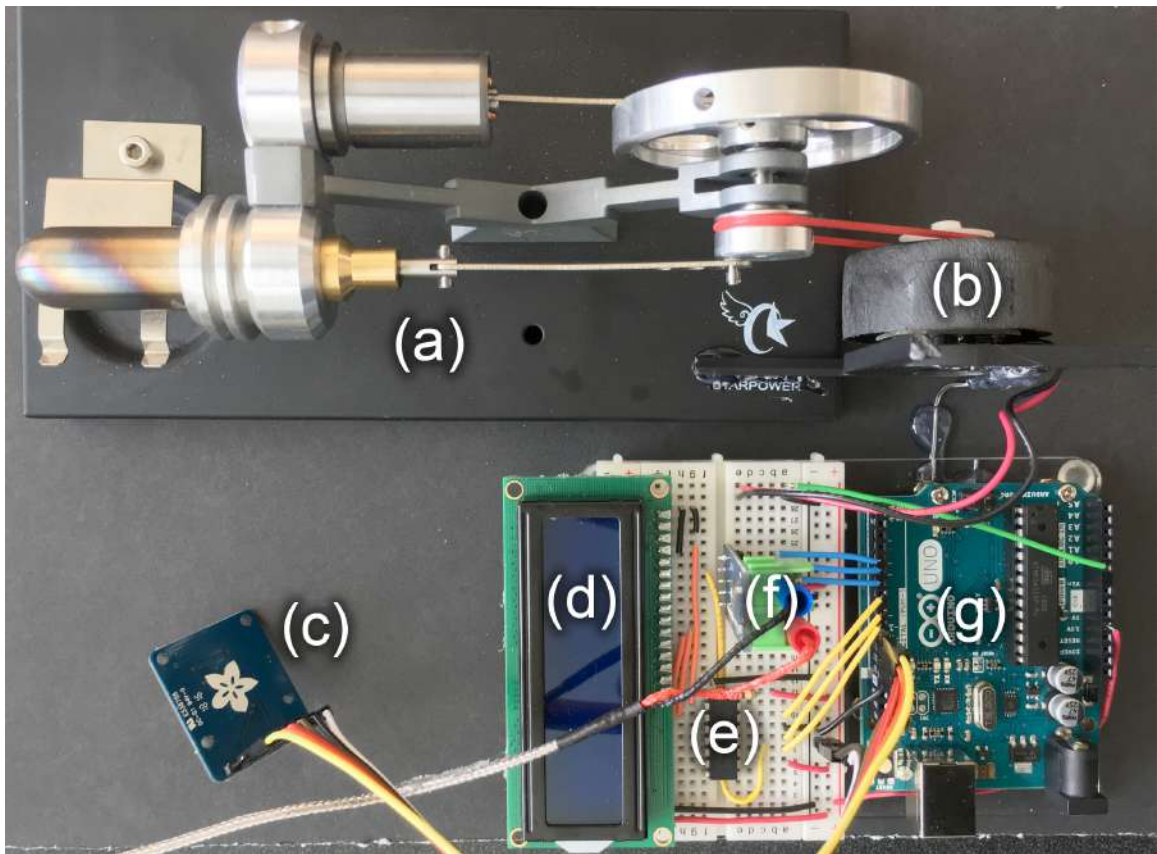

Figure 3.1: Figure of setup. (a) Stirling engine (b) brushless DC motor (c) microSD breakout board (d) LCD screen (e) 8-bit shift register (f) thermocouple module (g) Arduino UNO

3.1 Stirling Engine

While the experiment originally called for the development of a Stirling engine, one was not completed in time. Alternatively, the purchase of a Stirling engine by Sun-nytech allowed for more immediate data collection. In the original design, Borosilicate glass syringes were used as pistons because they can be used at high temperatures and the plunger makes an air-tight seal. The rest of the engine was machined out of aluminum, with some small parts such as the flywheels and gears made from plastic. Due to time constraints, this engine has yet to run.

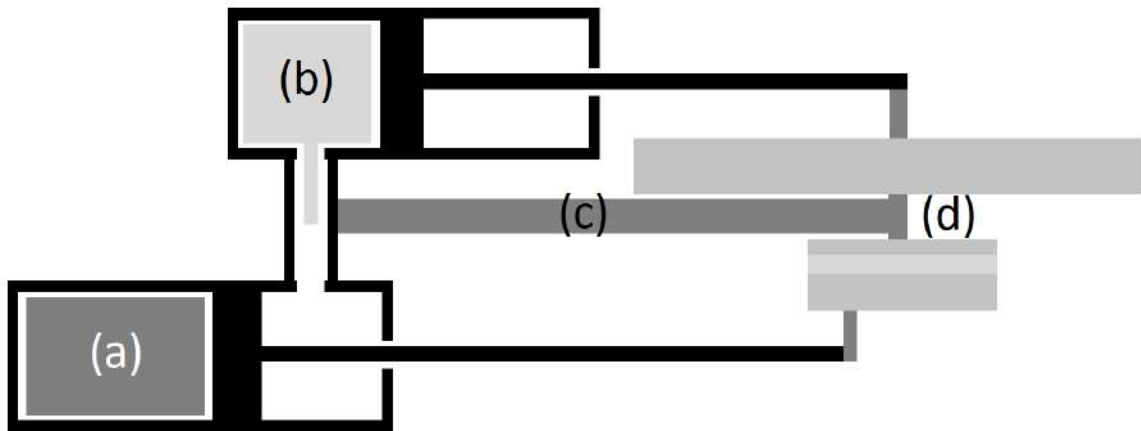

Figure 3.2: Simplified diagram of the Stirling engine used. Notice the oscillatory alignment of the pistons is such that they have a phase difference of $\frac{\pi}{2}$. (a) Hot piston (b) cold piston (c) brace to hold engine together (d) flywheels.

3.2 Solar Collector

An 8.3” by 11.75” Fresnel lens was used as the solar energy collector. The flat design of a Fresnel lens allowed for easy modification of the amount of light to be passed through the lens. As seen in Figure 3.3, slides of varying hole size were placed over the lens such that the area could be measured. The focal point of the solar collector setup was then positioned on the hot cylinder of the Stirling engine.

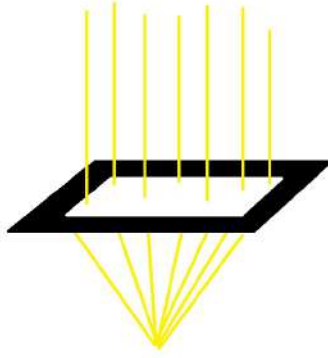

Figure 3.3: As light passes through the plane of the Fresnel lens, it converges to a focal point. The thick rectangle represents the apertures which were laid over the lens to modify the amount of light which passes through the lens.

3.3 Arduino Data Collection

An Arduino UNO microcontroller board was used for data collection due to its ability to read and write information and has many inputs and outputs. A K-type thermocouple with the Arduino MAX6675 module were used to read temperature data from the hot piston of the Stirling engine and send the information to the Arduino. A small brushless direct current (D.C.) motor taken from a computer fan was attached to the flywheel of the engine and ran in 'reverse' as a generator in order to produce a voltage. Since the brushless D.C. motor produces an alternating current (A.C.) when running in reverse, this voltage was passed through a full-wave rectifier to convert the A.C. to D.C. for easier data analysis. This voltage was used as the output from the system which was recorded. This then was read by an analog input pin of the Arduino. An Adafruit ADA254 MicroSD card breakout board was used to record data. The Arduino also output data to the IC74HC59N 8-bit shift register to run the LCM1602C LCD screen for a live data feed. These parts can be seen labeled in Figure 3.4.

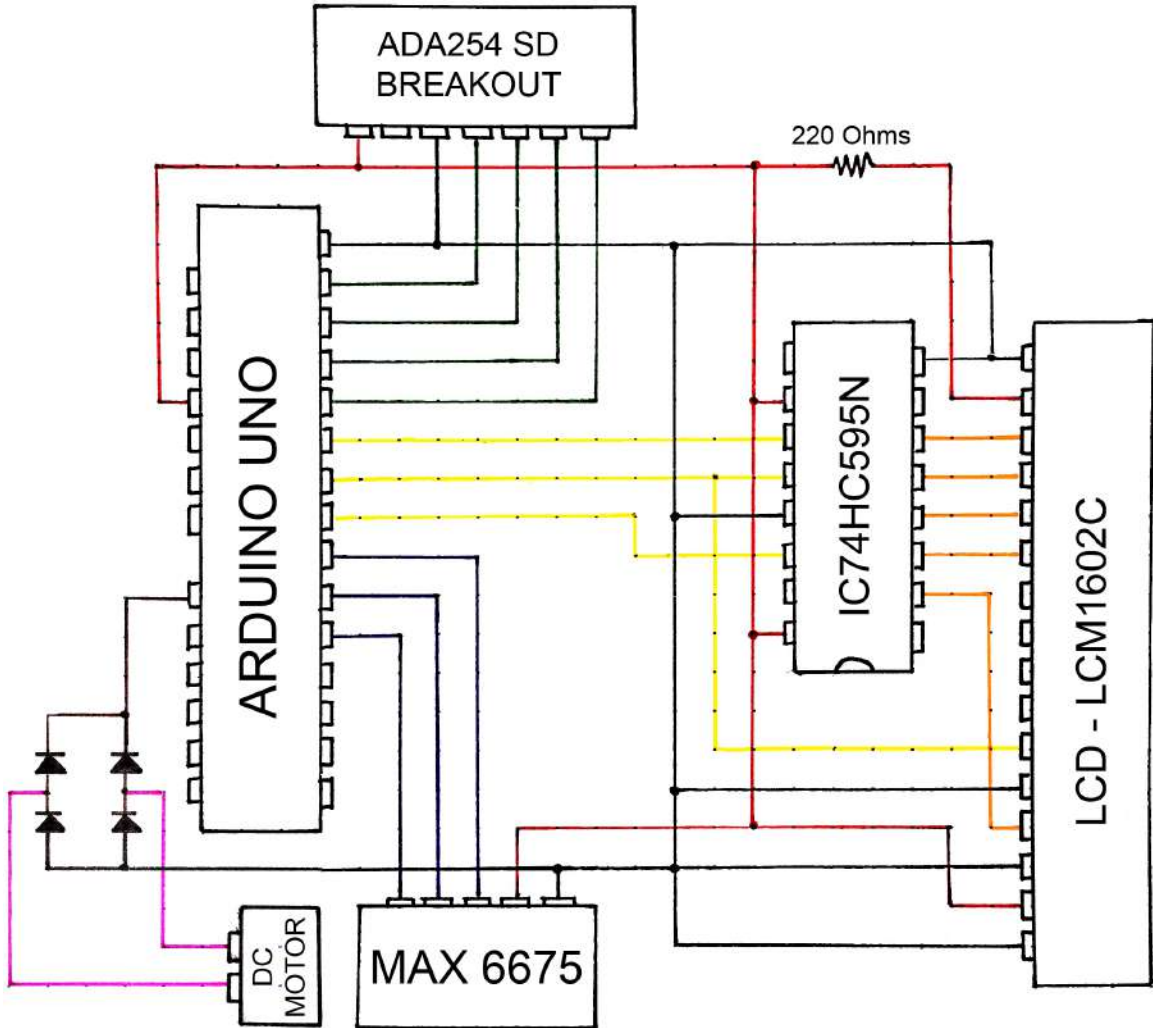

Figure 3.4: Circuit diagram of electrical components.

Chapter 4

Results

4.1 Data Collected

Data on the output of the engine and its temperature was recorded and plotted, as seen in Figure 4.1. Temperature data was taken every 200ms, while voltage was taken every 5ms.

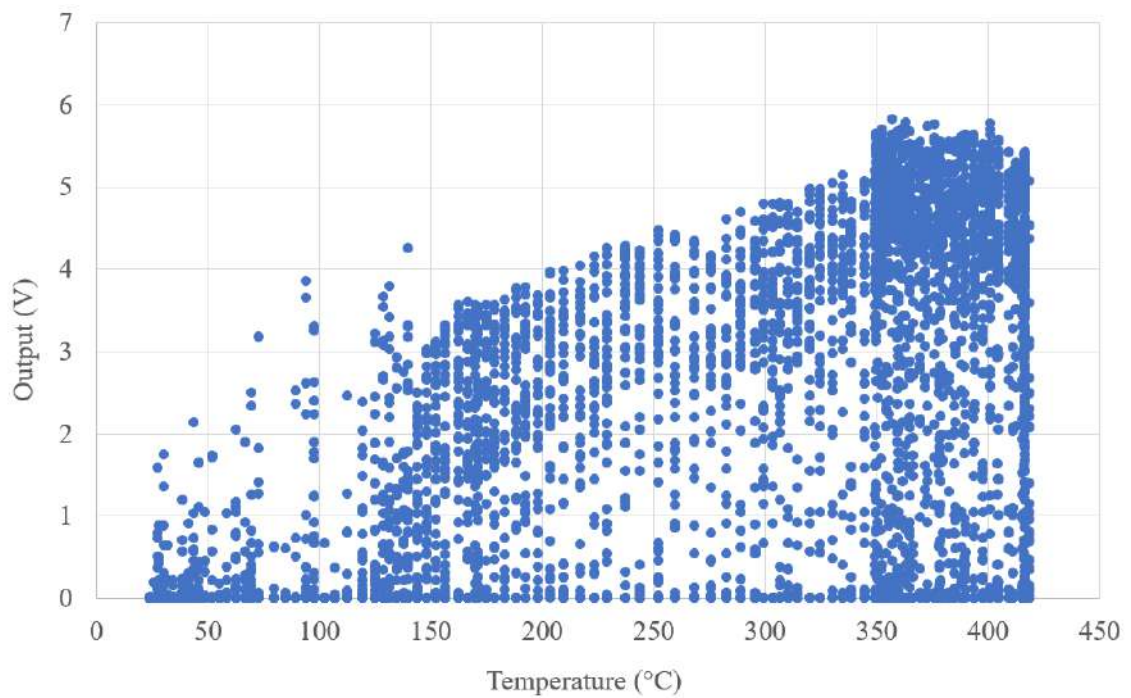

Figure 4.1: Output voltage versus Stirling engine temperature.

Additionally it is possible to plot the output by time, as seen in Figure 4.2. While this does not give information regarding the relationship between temperature and output, it is easier to see how the output changes over time:

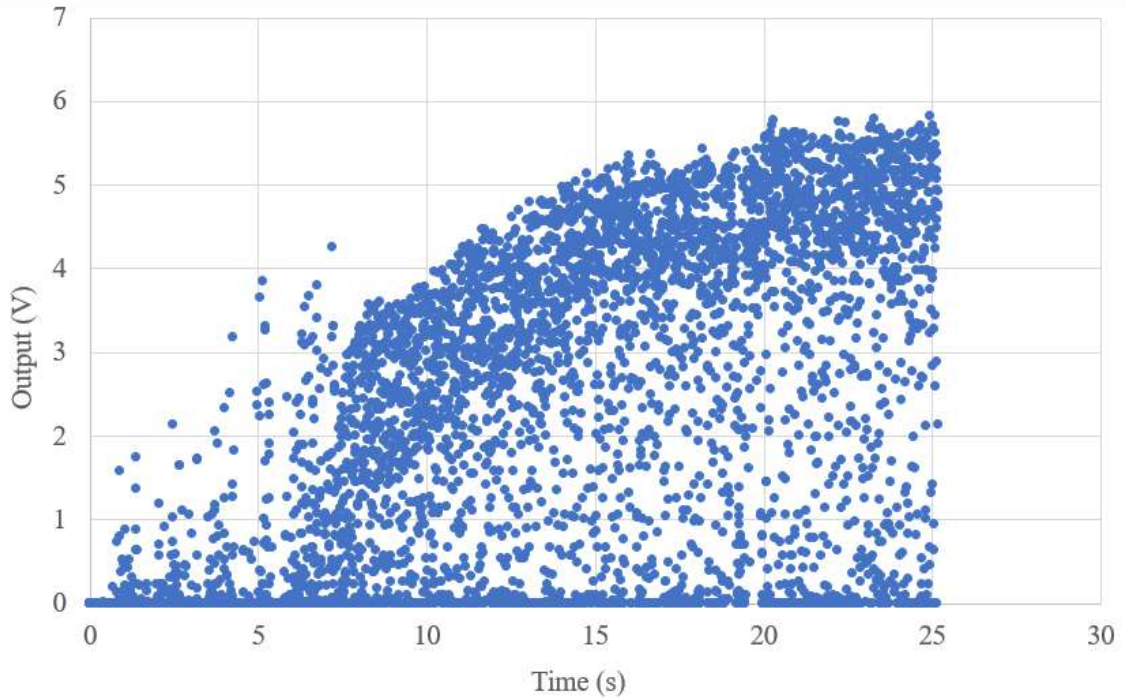

Figure 4.2: Output voltage versus time elapsed during data collection.

4.2 Analysis

This data appears noisy due to the A.C. output by the generator. A rectifier was placed with the output of the motor in order to turn negative voltages in to positive, thus the data here resembles a function:

$$V(t) = |V_{max}(t) \sin(\omega t)| \quad (4.1)$$

Where $V_{max}(t)$ is an increasing amplitude by time and ω is the angular frequency $2\pi f$, dependent on the angular velocity of the generator (i.e. how fast it is spinning). The rectifier thus changes the sinusoidal function from Figure 2.2 to resemble the

following:

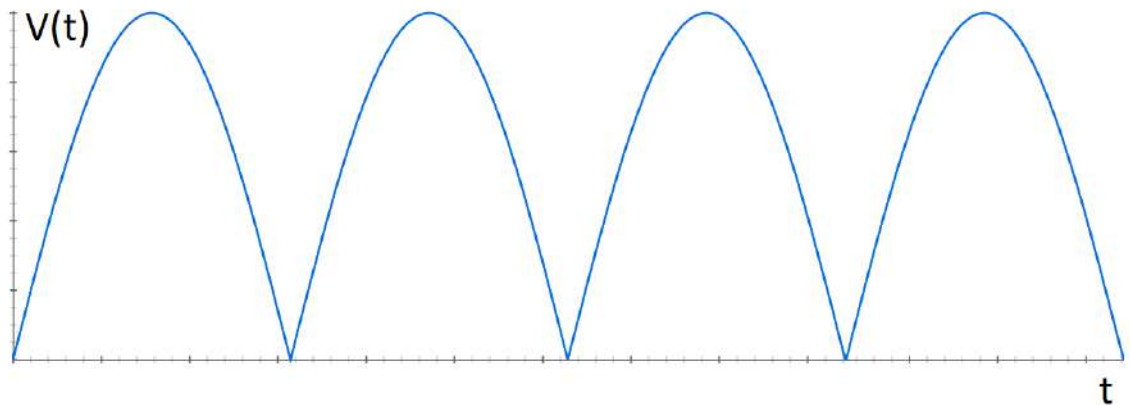

Figure 4.3: Output voltage after being sent through full wave rectifier.

In order to understand how this output is changing in Figure 4.1, only the maximum amplitudes will be analyzed. This means for each temperature, only the maximum value is considered. Experimentally, this can be done using a smoothing full wave rectifier. This could also be achieved by programming the Arduino to only take the maximum value over some time period.

Data appear in straight vertical lines of the same temperature due to the different data collection rates for the thermocouple and voltage readings. This was done during the coding process because the thermocouple has a minimum response rate of 200ms, while data needed to be recorded for voltage over a shorter time period, such as 5ms. Random data points appear in the temperature range of less than about 140°C due to attempting to jump-start the engine, which was a necessary step. An increased number of data points appear around 350°C and greater because this is the temperature range that the engine sat at for the longest time period.

Chapter 5

Conclusion

Although improvements are still needed, several statements can be made regarding the data collected which helps the understanding of the solar thermal power generation system and changes that can improve the experiment.

As seen in Figure 5.1, the output follows a relatively linear relationship as the temperature increases. At temperatures less than 110°C , the engine was not running. Any output data seen in this range is due to manually spinning the flywheel to jump-start the engine. In order to better understand the analysis of the data, the following is an interpretation using a line fit to the data:

By ignoring engine jump-start output data and outputs that are less than the maximum and fitting a trend line, there are a number of trends that can be noticed. In the range from about $110\text{-}160^{\circ}\text{C}$, output increases exponentially and then the increasing rate decreases. Near the lower end of this range an increase in temperature gives a much greater output, while near the upper end of this range an increase in temperature results in a decreasing return in output.

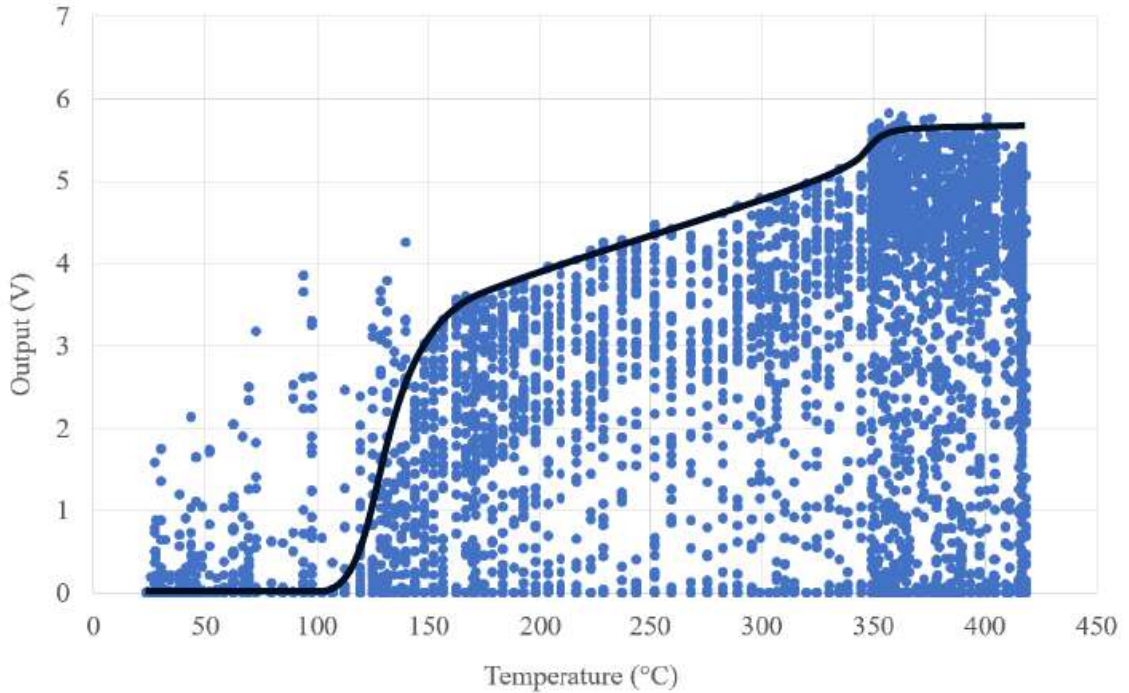

Figure 5.1: Output voltage versus Stirling engine temperature with manual trend line applied.

From 160-350°C, the output follows a very close linear function. This is interesting because not all of the data show the same relationship. Above 350°C, the output begins to reach a rough maximum of about 5.5V. Again, the density of this range can be explained when referring back to Figure 4.2.

To conclude, the operating temperature of this Stirling engine is most efficient given a variable temperature at 160°C. At slightly lower temperatures, the output is much less. At slightly higher temperatures, the output gained does not make the extra fuel worthwhile due to its small-slope linear relationship. Stirling engine-based solar power could be a viable form of alternative energy which utilizes sunlight.

5.1 Sources of Uncertainty

The issues to be addressed relate to the output from the generator and several other factors. The generator which produced the voltage output was not used as designed since it is actually a brushless D.C. motor running in reverse, therefore it did not run with optimal efficiency. In addition, the Stirling engine and its cycle is imperfect and inconsistent. A smaller system also means there is more uncertainty in the results.

5.2 Future Work

As this experiment was created from the ground-up, progress has been made to make a working small-scale prototype for a solar thermal Stirling engine. Once the current issues are resolved and proper data taken, the viability of this system can be further tested. This includes scaling, production cost, and optimization based on data collected. It would also be beneficial to test and improve the engine's efficiency of this system and compare it with modern solar cells.

Chapter 6

Appendix

6.1 Sample Arduino Code

The following is the loop of code the Arduino performs to read and record data.

```
void loop(){
    float celsius = ktc.readCelsius();
    float fahrenheit = ktc.readFahrenheit();
    for (i = 0; i < n; i++){
        float readOutput = analogRead(motorPin) * 15.0000 / 1024;
        delay(collectionRate);
    }
    // open or create celsiusData file on SD card and write to it
    celsiusFile = SD.open("celsius.txt", FILE_WRITE);
    if (celsiusFile){
        celsiusFile.println(celsius);
        celsiusFile.close(); // close the file
    } else {
        Serial.println("Error opening celsius.txt during loop.");
    }
}
```

```
// open or create outputData file on SD card and write to it
outputFile = SD.open("output.txt", FILE_WRITE);
if (outputFile){
outputFile.println(output);
outputFile.close(); // close the file
} else {
    Serial.println("Error opening output.txt during loop.");
}
// print live temperature and output data in serial monitor
Serial.print(celsius); Serial.println(" C");
Serial.print(fahrenheit); Serial.println(" F");
Serial.print(output);
Serial.println(" V");
}
```

Chapter 7

Acknowledgements

I would like to thank my parents Cari Beck and Tom Beck who have made it possible for me to receive an incredible education in something I love. I appreciate everyone who has been a part of my life at Linfield College, such as my friends from the first week of freshman year: Rosa Johnson, Alex Andreotti, Andrew Free, Emily Culley, and those who came later such as Sarah Becker, Kyle Sharrer, and many more. To all who I have spent countless hours working on physics assignments with in Graf Hall. Most importantly, my supportive professors in the Linfield College Physics Department: Dr. Michael Crosser, Dr. Jennifer Heath, Dr. Bill Mackie, Dr. Joelle Murray, and Dr. Tianbao Xie. With all these people and many more, they have become a part of my Linfield family.

References

- [1] O. Ataer and H. Karabulut, *International Journal of Refrigeration* **28**, 183 (2005).
- [2] L. C. J. Chen, Z. Yan and B. Andresen, *International Journal of Energy Research* **22**, 805 (1998).
- [3] https://eia.gov/energyexplained/?page=solar_thermal_power_plants.
- [4] http://energy.gov/sites/prod/files/2014/05/f15/2014_csp_report.pdf.
- [5] R. A. Ristinen and J. J. Kraushaar, *Energy and the Environment* (John Wiley & Sons, New York, 1999).
- [6] D. V. Schroeder, *An Introduction to Thermal Physics* (Addison Wesley Longman, San Francisco, 2000).
- [7] <http://hyperphysics.phy-astr.gsu.edu/hbase/magnetic/motorac.html>.